

30 SEPTEMBER 1976

TM 11-5805-583-15LD

TECHNICAL MANUAL
Plastic Laminated Diagrams for Direct
and General Support Maintenance
CENTER, COMMUNICATIONS, PATCHING AN/TSC-76
(NSN 5895-00-168-1574)

NOTICE TO USERS

This package contains five diagrams from TM 11-5805-583-15 that have been plastic laminated for use in the maintenance of Center, Communications, Patching AN/ TSC-76. The package also contains a questionnaire on the Usability of Plastic Laminated Diagrams. To help us evaluate the usability of these diagrams, please fill out the questionnaire, fold it where shown, and drop it in the mail.

If your package has no questionnaire, you can still express your opinion on the usability of the diagrams by submitting comments and recommendations using DA Form 2028 (Recommended Changes to Publications and Blank Forms). Send to Commander, US Army Electronics Command, ATTN: DRSEL-MA-Q, Fort Monmouth, New Jersey 07703.

CONTENTS

Figure 5-3 ,	AN/TSC-76 Power Distribution Wiring Diagram.
Figure 5-4 ①.	AN/TSC-76 Signal Schematic Diagram (Sheet 1 of 4).
Figure 5-4 ②.	AN/TSC-76 Signal Schematic Diagram (Sheet 2 of 4).
Figure 5-4 ③.	AN/TSC-76 Signal Schematic Diagram (Sheet 3 of 4).
Figure 5-4 ④.	AN/TSC-76 Signal Schematic Diagram (Sheet 4 of 4).

By Order of the Secretary of the Army

FRED C. WEYAND
General, United States Army
Chief of Staff

Official:

PAUL T. SMITH
Major General, United States Army
The Adjutant General

QUESTIONNAIRE ON:
USABILITY OF PLASTIC-LAMINATED DIAGRAMMS

INSTRUCTIONS: 1. PLACE CHECK MARK OR X IN THE BLANK SPACE THAT BEST DESCRIBES YOUR EVALUATION OF THE USABILITY OF THE DIAGRAMMS. ADDITIONAL COMMENTS MAY BE INCLUDED WHERE INDICATED ON THE QUESTIONNAIRE.
2. FOLD THE COMPLETED QUESTIONNAIRE WHERE SHOWN AND DROP IT IN THE MAIL.

① DID YOU FIND THE PLASTIC-LAMINATED DIAGRAMMS MORE USABLE IN YOUR WORK THAN CONVENTIONAL PAPER DIAGRAMMS?

COMMENTS:

YES

NO

② WHERE WOULD YOU LIKE TO SEE MORE PLASTIC-LAMINATED DIAGRAMMS?

COMMENTS:

AS PART OF

THE TM

ISSUED

SEPARATELY

PACKED WITH

THE EQUIPMENT

③ WHAT DO YOU THINK OF THE THICKNESS OF THE LAMINATE?

COMMENTS:

TOO

THIN

TOO

THICK

JUST

RIGHT

④ WHAT TYPES OF DIAGRAMMS DO YOU THINK ARE BEST SUITED FOR PLASTIC LAMINATION?

COMMENTS:

SCHEMATIC

WIRING

BLOCK

OTHER
(EXPLAIN)

⑤ DO YOU HAVE ANY RECOMMENDATIONS FOR MAKING DIAGRAMMS MORE USABLE IN YOUR TYPE OF WORK?

COMMENTS:

YES

NO

FROM : _____ UNIT _____
NAME ADDRESS

FILL IN YOUR
UNIT'S ADDRESS

FOLD BACK

DEPARTMENT OF THE ARMY

OFFICIAL BUSINESS
PENALTY FOR PRIVATE USE, \$300

POSTAGE AND FEES PAID
DEPARTMENT OF THE ARMY
DOD-314



Commander
US Army Electronics Command
ATTN: DRSEL-MA-Q
Fort Monmouth, New Jersey 07703

FOLD BACK

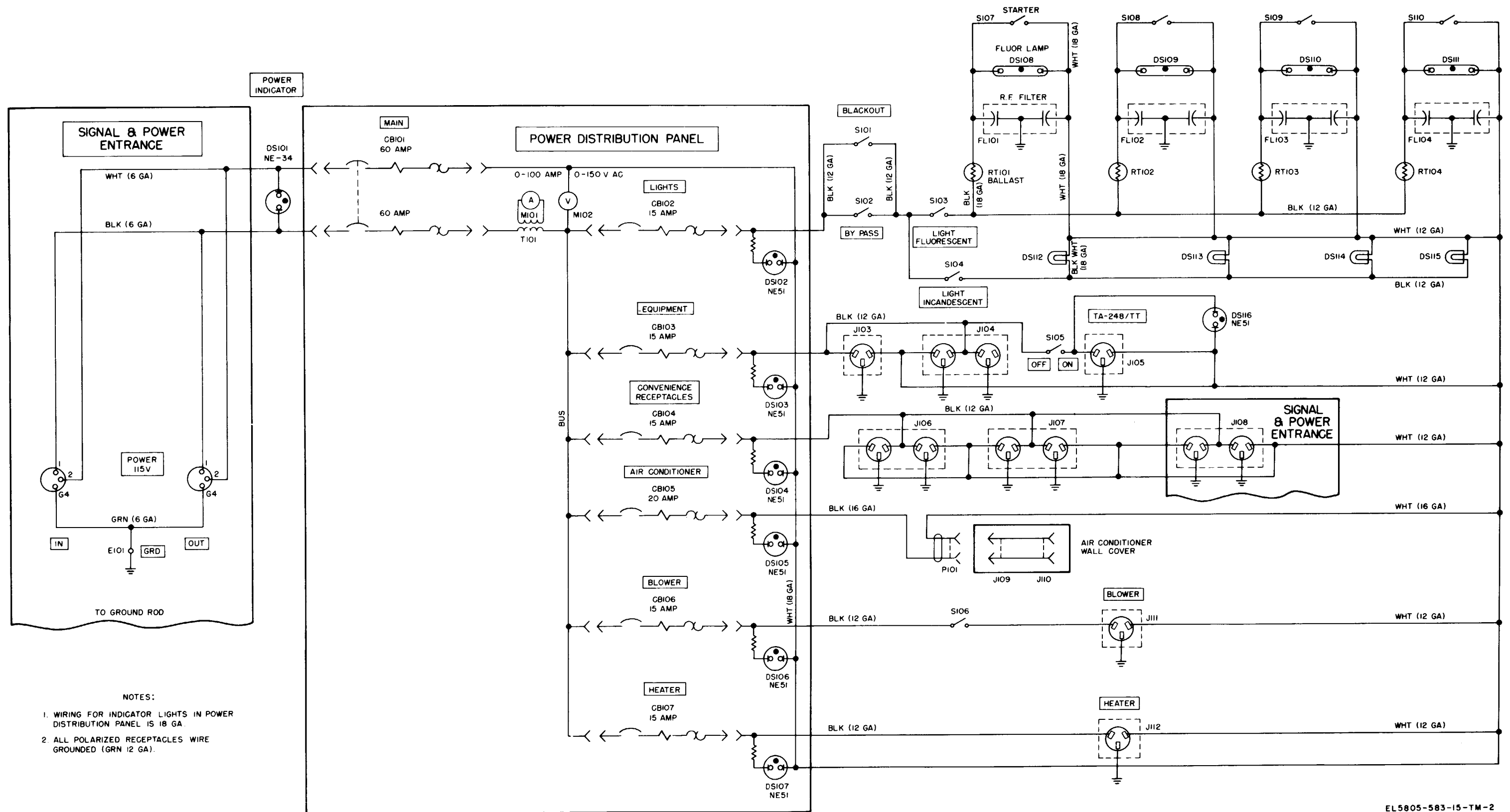

FIGURE 5-3. AN/TSC-76 POWER DISTRIBUTION WIRING DIAGRAM.

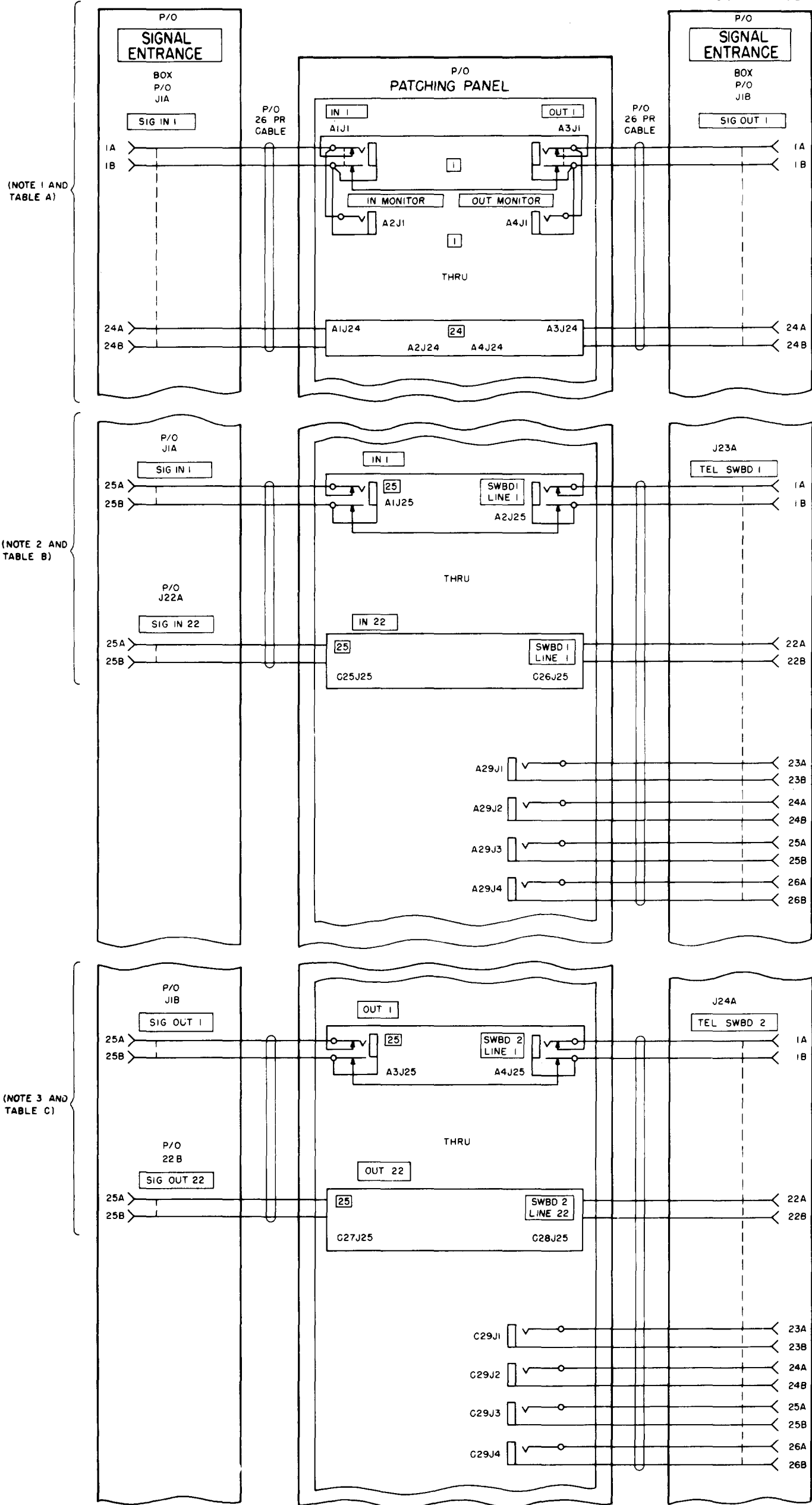

FIGURE 5-4 (1). AN/TSC-76 SIGNAL SCHEMATIC DIAGRAM (SHEET 1 OF 4).

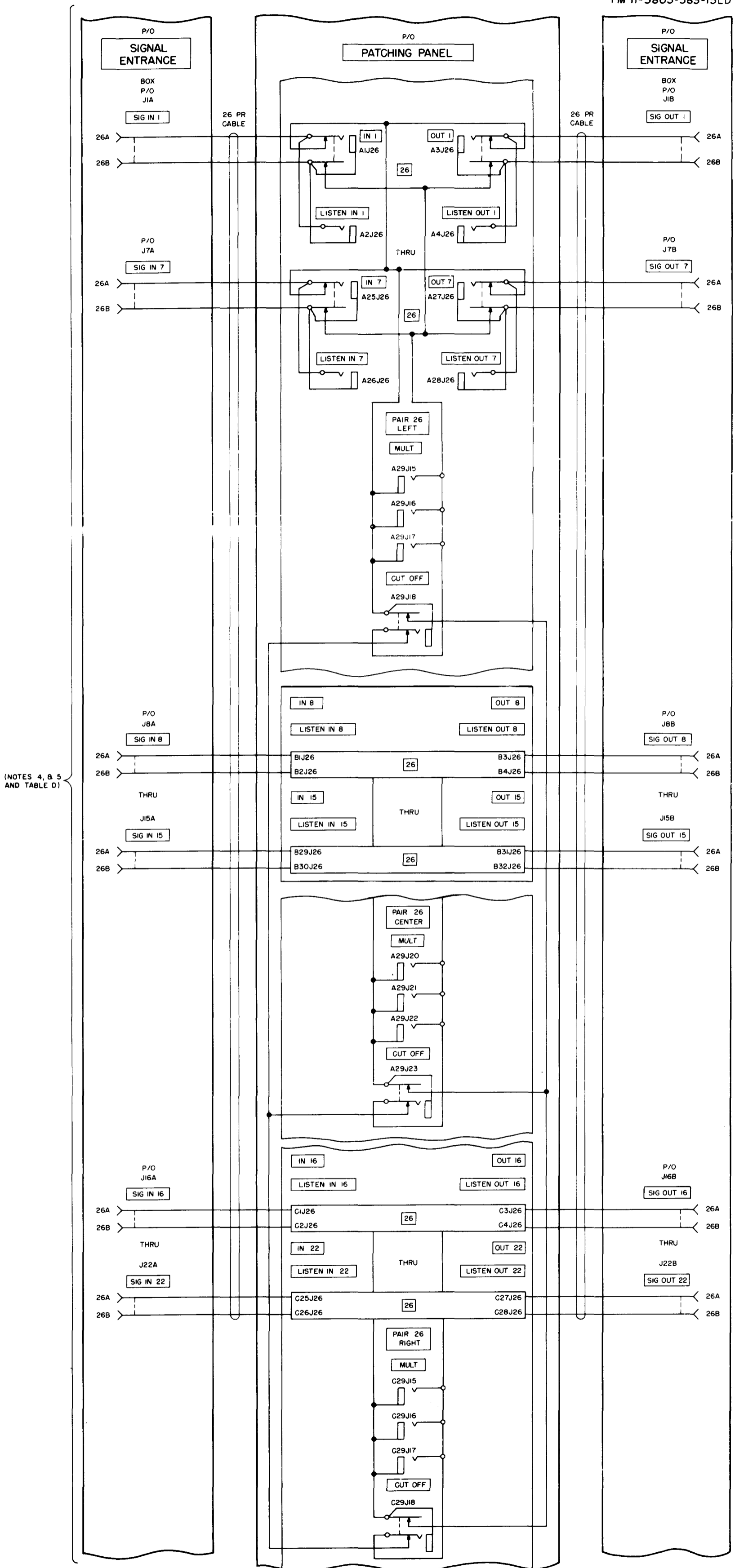

FIGURE 5-4 (2). AN/TSC-76 SIGNAL SCHEMATIC DIAGRAM (SHEET 2 OF 4).

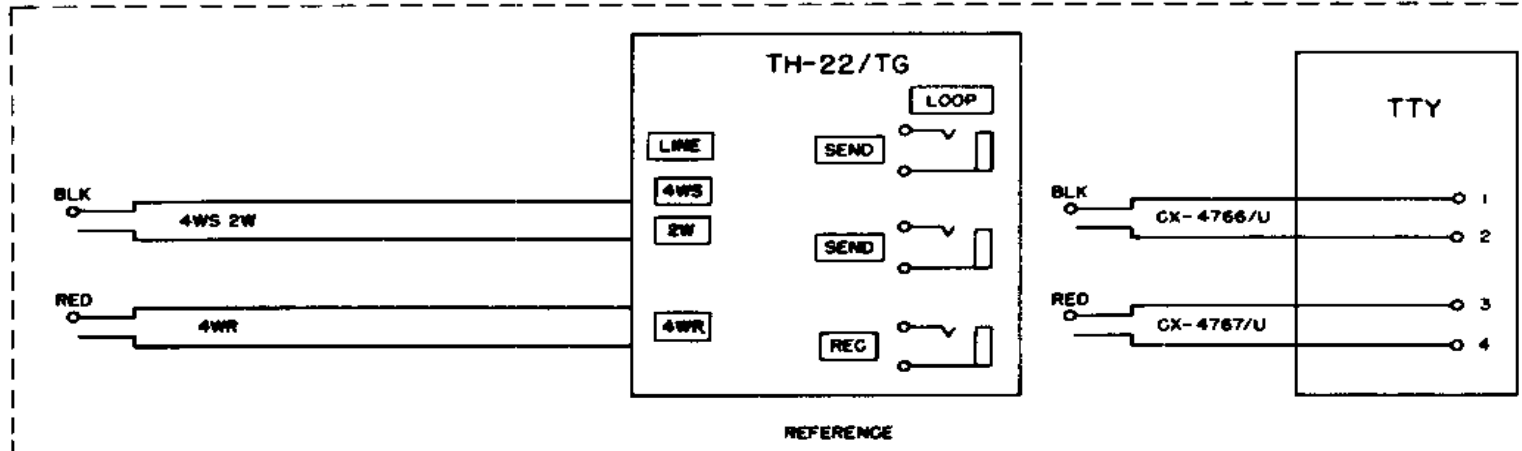
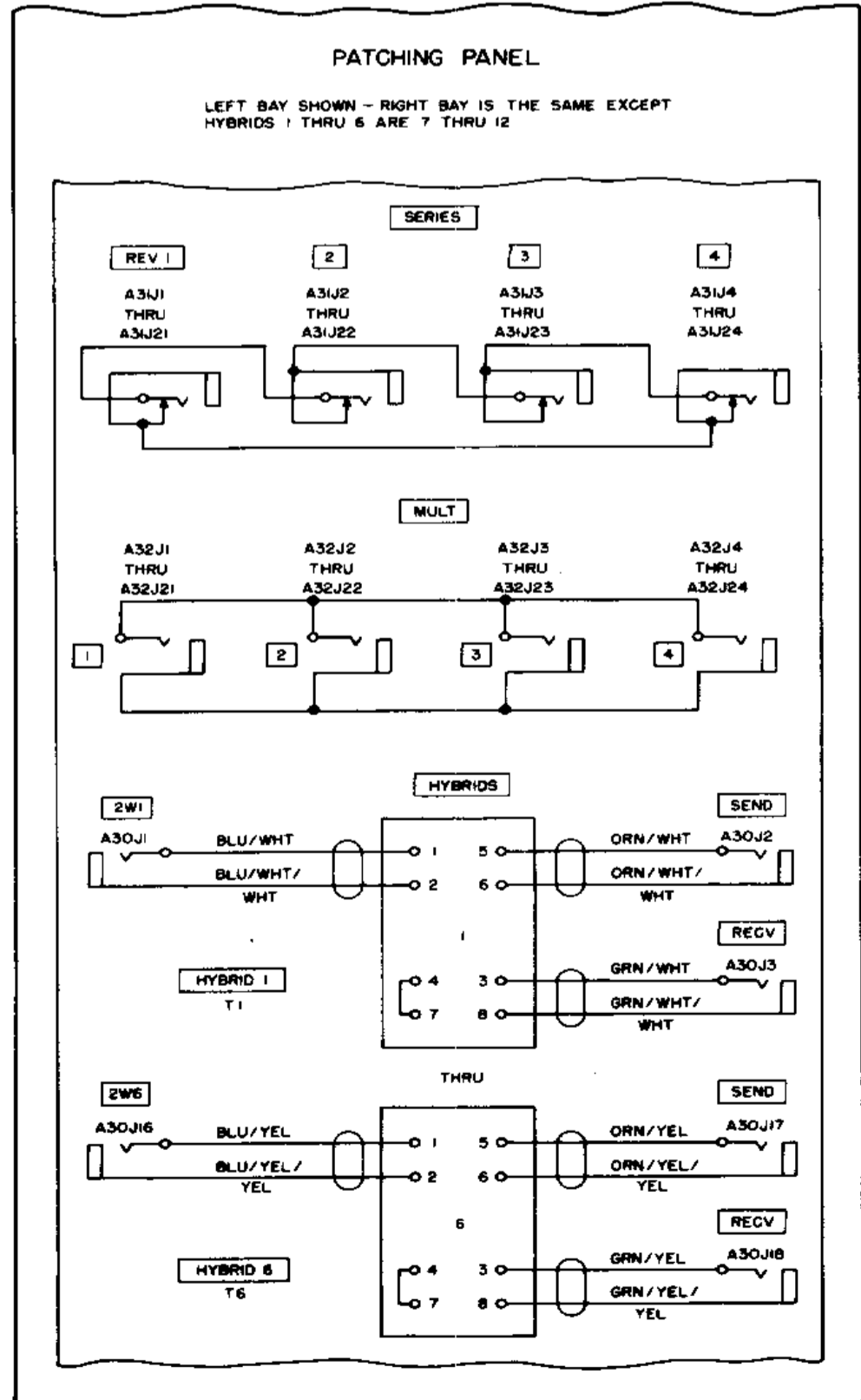
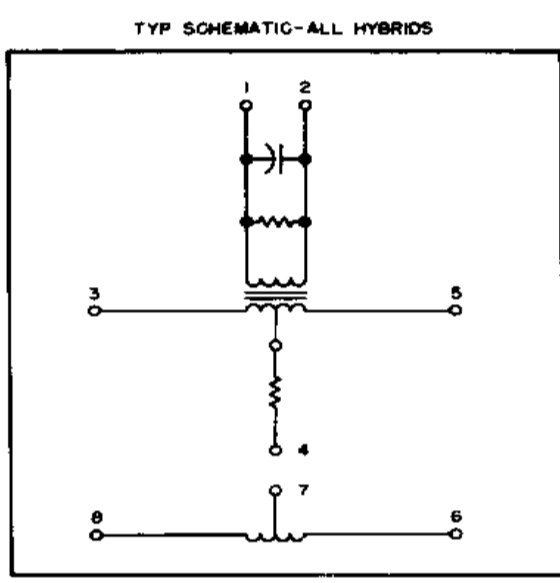
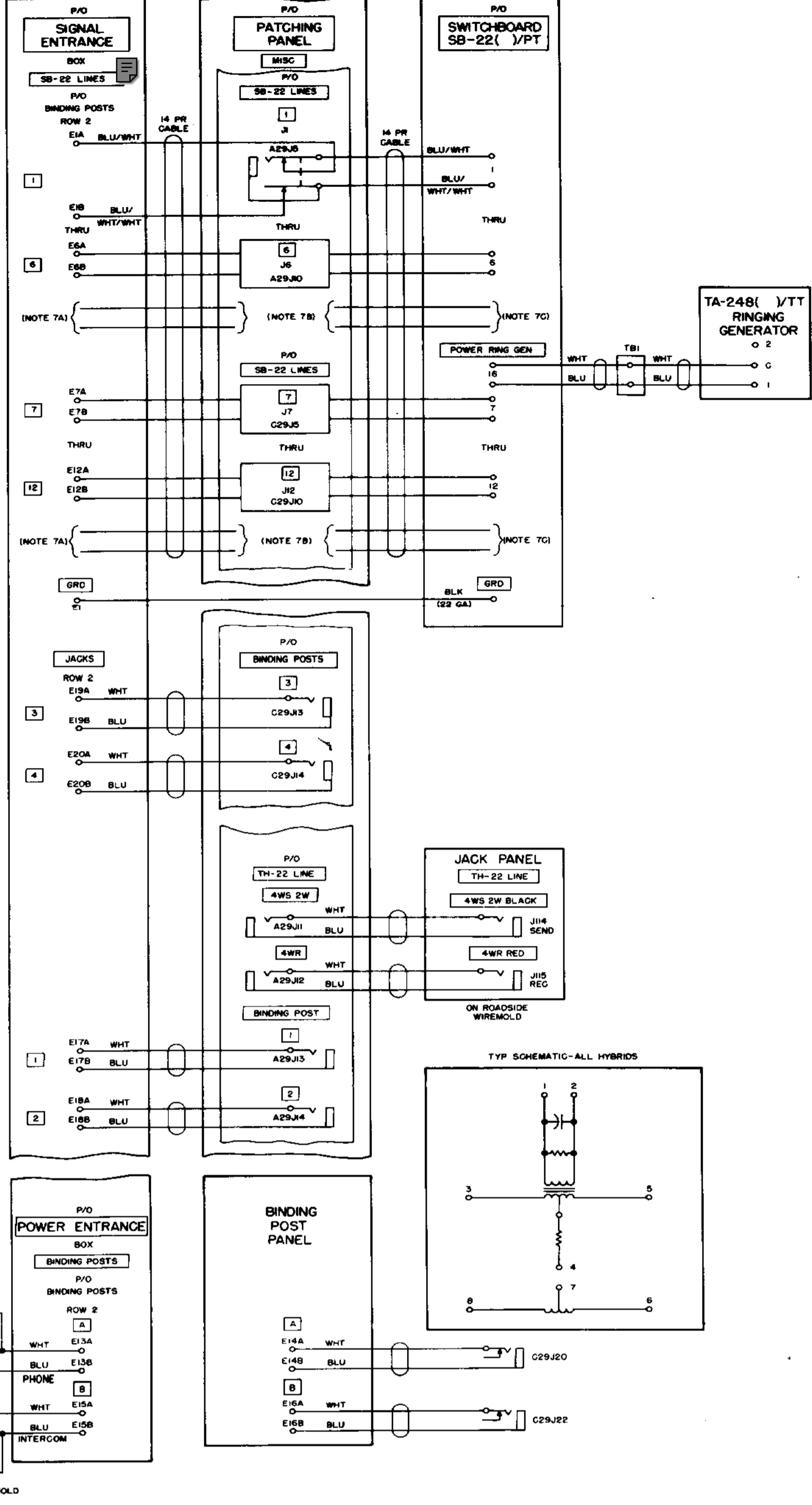

FIGURE 5-4 (3). AN/TSC-76 SIG SCHEMATIC DIAGRAM (SHEET 3 OF 4).

TABLE A											
26-PR RECP		JACK DESIGNATION								26-PR RECP	
EQUIP MARKING	REF DESIGNATION	IN		IN MONITOR		OUT MONITOR		OUT		REF DESIGNATION	EQUIP MARKING
		LEFT BAY									
SIG IN 1	J1A	A1J1	A1J24	A2J1	A2J24	A4J1	A4J24	A3J1	A3J24	J1B	SIG OUT 1
SIG IN 2	J2A	A5J1	A5J24	A6J1	A6J24	A8J1	A8J24	A7J1	A7J24	J2B	SIG OUT 2
SIG IN 3	J3A	A9J1	A9J24	A10J1	A10J24	A12J1	A12J24	A11J1	A11J24	J3B	SIG OUT 3
SIG IN 4	J4A	A13J1	A13J24	A14J1	A14J24	A16J1	A16J24	A15J1	A15J24	J4B	SIG OUT 4
SIG IN 5	J5A	A17J1	A17J24	A18J1	A18J24	A20J1	A20J24	A19J1	A19J24	J5B	SIG OUT 5
SIG IN 6	J6A	A21J1	A21J24	A22J1	A22J24	A24J1	A24J24	A23J1	A23J24	J6B	SIG OUT 6
SIG IN 7	J7A	A25J1	A25J24	A26J1	A26J24	A28J1	A28J24	A27J1	A27J24	J7B	SIG OUT 7
CENTER BAY											
SIG IN 8	J8A	B1J1	B1J24	B2J1	B2J24	B4J1	B4J24	B3J1	B3J24	J8B	SIG OUT 8
SIG IN 9	J9A	B5J1	B5J24	B6J1	B6J24	B8J1	B8J24	B7J1	B7J24	J9B	SIG OUT 9
SIG IN 10	J10A	B9J1	B9J24	B10J1	B10J24	B12J1	B12J24	B11J1	B11J24	J10B	SIG OUT 10
SIG IN 11	J11A	B13J1	B13J24	B14J1	B14J24	B16J1	B16J24	B15J1	B15J24	J11B	SIG OUT 11
SIG IN 12	J12A	B17J1	B17J24	B18J1	B18J24	B20J1	B20J24	B19J1	B19J24	J12B	SIG OUT 12
SIG IN 13	J13A	B21J1	B21J24	B22J1	B22J24	B24J1	B24J24	B23J1	B23J24	J13B	SIG OUT 13
SIG IN 14	J14A	B25J1	B25J24	B26J1	B26J24	B28J1	B28J24	B27J1	B27J24	J14B	SIG OUT 14
SIG IN 15	J15A	B29J1	B29J24	B30J1	B30J24	B32J1	B32J24	B31J1	B31J24	J15B	SIG OUT 15
RIGHT BAY											
SIG IN 16	J16A	C1J1	C1J24	C2J1	C2J24	C4J1	C4J24	C3J1	C3J24	J16B	SIG OUT 16
SIG IN 17	J17A	C5J1	C5J24	C6J1	C6J24	C8J1	C8J24	C7J1	C7J24	J17B	SIG OUT 17
SIG IN 18	J18A	C9J1	C9J24	C10J1	C10J24	C12J1	C12J24	C11J1	C11J24	J18B	SIG OUT 18
SIG IN 19	J19A	C13J1	C13J24	C14J1	C14J24	C16J1	C16J24	C15J1	C15J24	J19B	SIG OUT 19
SIG IN 20	J20A	C17J1	C17J24	C18J1	C18J24	C20J1	C20J24	C19J1	C19J24	J20B	SIG OUT 20
SIG IN 21	J21A	C21J1	C21J24	C22J1	C22J24	C24J1	C24J24	C23J1	C23J24	J21B	SIG OUT 21
SIG IN 22	J22A	C25J1	C25J24	C26J1	C26J24	C28J1	C28J24	C27J1	C27J24	J22B	SIG OUT 22

TABLE B					
26 PR RECP		JACK DESIGNATION		26 PR RECP	
EQUIP MARKING	REF DESIGNATION	IN	SWBD 1	J23A CONTACT DESIGNATIONS	
				LEFT BAY	RIGHT BAY
SIG IN 1	J1A	A1J25	A2J25	1A&B	
SIG IN 2	J2A	A5J25	A6J25	2A&B	
SIG IN 3	J3A	A9J25	A10J25	3A&B	
SIG IN 4	J4A	A13J25	A14J25	4A&B	
SIG IN 5	J5A	A17J25	A18J25	5A&B	
SIG IN 6	J6A	A21J25	A22J25	6A&B	
SIG IN 7	J7A	A25J25	A26J25	7A&B	
SIG IN 8	J8A	B1J25	B2J25	8A&B	
SIG IN 9	J9A	B5J25	B6J25	9A&B	
SIG IN 10	J10A	B9J25	B10J25	10A&B	
SIG IN 11	J11A	B13J25	B14J25	11A&B	
SIG IN 12	J12A	B17J25	B18J25	12A&B	
SIG IN 13	J13A	B21J25	B22J25	13A&B	
SIG IN 14	J14A	B25J25	B26J25	14A&B	
SIG IN 15	J15A	B29J25	B30J25	15A&B	
SIG IN 16	J16A	C1J25	C2J25	16A&B	
SIG IN 17	J17A	C5J25	C6J25	17A&B	
SIG IN 18	J18A	C9J25	C10J25	18A&B	
SIG IN 19	J19A	C13J25	C14J25	19A&B	
SIG IN 20	J20A	C17J25	C18J25	20A&B	
SIG IN 21	J21A	C21J25	C22J25	21A&B	
SIG IN 22	J22A	C25J25	C26J25	22A&B	

TABLE D							
26 PR RECP		JACK DESIGNATION				26 PR RECP	
EQUIP MARKING	REF DESIGNATION	IN	LISTEN IN	LISTEN OUT	OUT	REF DESIGNATION	EQUIP MARKING
SIG IN 1	J1A	A1J26	A2J26	A4J26	A3J26	J1B	SIG OUT 1
SIG IN 2	J2A	A5J26	A6J26	A8J26	A7J26	J2B	SIG OUT 2
SIG IN 3	J3A	A9J26	A10J26	A12J26	A11J26	J3B	SIG OUT 3
SIG IN 4	J4A	A13J26	A14J26	A16J26	A15J26	J4B	SIG OUT 4
SIG IN 5	J5A	A17J26	A18J26	A20J26	A19J26	J5B	SIG OUT 5
SIG IN 6	J6A	A21J26	A22J26	A24J26	A23J26	J6B	SIG OUT 6
SIG IN 7	J7A	A25J26	A26J26	A28J26	A27J26	J7B	SIG OUT 7
CENTER BAY							
SIG IN 8	J8A	B1J26	B2J26	B4J26	B3J26	J8B	SIG OUT 8
SIG IN 9	J9A	B5J26	B6J26	B8J26	B7J26	J9B	SIG OUT 9
SIG IN 10	J10A	B9J26	B10J26	B12J26	B11J26	J10B	SIG OUT 10
SIG IN 11	J11A	B13J26	B14J26	B16J26	B15J26	J11B	SIG OUT 11
SIG IN 12	J12A	B17J26	B18J26	B20J26	B19J26	J12B	SIG OUT 12
SIG IN 13	J13A	B21J26	B22J26	B24J26	B23J26	J13B	SIG OUT 13
SIG IN 14	J14A	B25J26	B26J26	B28J26	B27J26	J14B	SIG OUT 14
SIG IN 15	J15A	B29J26	B30J26	B32J26	B31J26	J15B	SIG OUT 15
RIGHT BAY							
SIG IN 16	J16A	C1J26	C2J26	C4J26	C3J26	J16B	SIG OUT 16
SIG IN 17	J17A	C5J26	C6J26	C8J26	C7J26	J17B	SIG OUT 17
SIG IN 18	J18A	C9J26	C10J26	C12J26	C11J26	J18B	SIG OUT 18
SIG IN 19	J19A	C13J26	C14J26	C16J26	C15J26	J19B	SIG OUT 19
SIG IN 20	J20A	C17J26	C18J26	C20J26	C19J26	J20B	SIG OUT 20
SIG IN 21	J21A	C21J26	C22J26	C24J26	C23J26	J21B	SIG OUT 21
SIG IN 22	J22A	C25J26	C26J26	C28J26	C27J26	J22B	SIG OUT 22

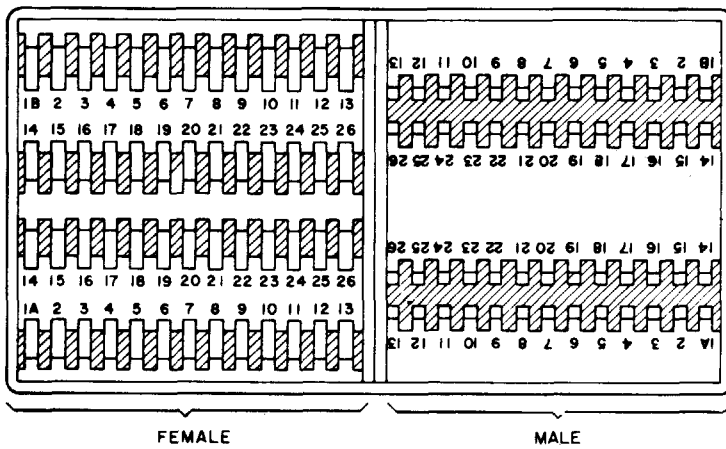

DIAGRAM OF UG 187

TABLE C					
26 PR RECP		JACK DESIGNATION		26 PR RECP	
EQUIP MARKING	REF DESIGNATION	OUT	SWBD 2	J24A CONTACT DESIGNATIONS	
				LEFT BAY	RIGHT BAY
SIG OUT 1	J1B	A3J25	A4J25	1A&B	
SIG OUT 2	J2B	A7J25	A8J25	2A&B	
SIG OUT 3	J3B	A11J25	A12J25	3A&B	
SIG OUT 4	J4B	A15J25	A16J25	4A&B	
SIG OUT 5	J5B	A19J25	A20J25	5A&B	
SIG OUT 6	J6B	A23J25	A24J25	6A&B	
SIG OUT 7	J7B	A27J25	A28J25	7A&B	
SIG OUT 8	J8B	B3J25	B4J25	8A&B	
SIG OUT 9	J9B	B7J25	B8J25	9A&B	
SIG OUT 10	J10B	B11J25	B12J25	10A&B	
SIG OUT 11	J11B	B15J25	B16J25	11A&B	
SIG OUT 12	J12B	B19J25	B20J25	12A&B	
SIG OUT 13	J13B	B23J25	B24J25	13A&B	
SIG OUT 14	J14B	B27J25	B28J25	14A&B	
SIG OUT 15	J15B	B31J25	B32J25	15A&B	
SIG OUT 16	J16B	C3J25	C4J25	16A&B	
SIG OUT 17	J17B	C7J25	C8J25	17A&B	
SIG OUT 18	J18B	C11J25	C12J25	18A&B	
SIG OUT 19	J19B	C15J25	C16J25	19A&B	
SIG OUT 20	J20B	C19J25	C20J25	20A&B	
SIG OUT 21	J21B	C23J25	C24J25	21A&B	
SIG OUT 22	J22B	C27J25	C28J25	22A&B	

NOTE:

- SHOWS SIG IN 1 AND SIG OUT 1 RECEPTACLES ONLY. SIG IN 2 THRU SIG IN 22 AND SIG OUT 2 THRU SIG OUT 22 RECEPTACLES ARE WIRED IDENTICALLY. SEE TABLE A FOR CORRESPONDING JACK DESIGNATIONS.
- SHOWS J23A TEL SWBD 1 RECEPTACLES 1 AND 22. RECEPTACLES 1 THRU 22 ARE WIRED IDENTICALLY. SEE TABLE B FOR CORRESPONDING JACK DESIGNATIONS.
- SHOWS J24A TEL SWBD 2 RECEPTACLES 1 AND 22. RECEPTACLES 1 THRU 22 ARE WIRED IDENTICALLY. SEE TABLE C FOR CORRESPONDING JACK DESIGNATIONS.
- SHOWS SIG IN 1 THRU SIG IN 7 AND SIG OUT 1 THRU SIG OUT 7. SIG IN 1 THRU SIG IN 22 AND SIG OUT 1 THRU SIG OUT 22 RECEPTACLES ARE WIRED IDENTICALLY. SEE TABLE D FOR CORRESPONDING JACK DESIGNATIONS.
- PATCHING PANEL WIRING FOR IN 8, OUT 8 THRU IN 15, OUT 15 AND IN 16, OUT 16 THRU IN 22, OUT 22 IS IDENTICAL TO IN 1, OUT 1 THRU IN 7, OUT 7.
- SHOWS TERMINAL POSTS 1 THRU 6 AND 7 THRU 12. TERMINAL POSTS 1 THRU 12 ARE WIRED IDENTICALLY.
- SPARE WIRES ARE AS FOLLOWS:
 - TURNED BACK & TAPED IN SIGNAL ENTRANCE BOX
 - TURNED BACK & TAPED IN PATCHING PANEL
 - TURNED BACK & TAPED IN SWITCHBOARD
-
- SEE CONNECTOR UG/187 FOR WIRE COLOR CODE FOR ALL 26 PAIR CABLES.
- WIRE COLORS FOR 14 PAIR CABLES ARE THE SAME AS PAIR 1 THRU 14 IN CONNECTOR UG/187.
- ALL WIRING IS 24 GA UNLESS OTHERWISE SPECIFIED.
- INDICATES EQUIPMENT MARKING.
- 26 PAIR RECEPTACLE IS VIEWED FROM PIN & SOCKET SIDE.
- PREFIX LETTERS OF JACK DESIGNATIONS INDICATE EITHER LEFT BAY (A), CENTER BAY (B) OR RIGHT BAY (C).
- ONLY FEMALE CONTACTS () OF 26 PAIR RECEPTACLES ARE SHOWN. EACH FEMALE CONTACT IS CONNECTED IN PARALLEL WITH A MALE CONTACT ()

FIGURE 5-4 (4) AN/TSC-76 SIGNAL SCHEMATIC DIAGRAM (SHEET 4 OF 4).

THE METRIC SYSTEM AND EQUIVALENTS

WEIGHT MEASURE

1 Centimeter = 10 Millimeters = 0.01 Meters = 0.3937 Inches
 1 Meter = 100 Centimeters = 1000 Millimeters = 39.37 Inches
 1 Kilometer = 1000 Meters = 0.621 Miles

WEIGHTS

1 Gram = 0.001 Kilograms = 1000 Milligrams = 0.035 Ounces
 1 Kilogram = 1000 Grams = 2.2 lb.
 1 Metric Ton = 1000 Kilograms = 1 Megagram = 1.1 Short Tons

LIQUID MEASURE

1 Milliliter = 0.001 Liters = 0.0338 Fluid Ounces
 1 Liter = 1000 Milliliters = 33.82 Fluid Ounces

SQUARE MEASURE

1 Sq. Centimeter = 100 Sq. Millimeters = 0.155 Sq. Inches
 1 Sq. Meter = 10,000 Sq. Centimeters = 10.76 Sq. Feet
 1 Sq. Kilometer = 1,000,000 Sq. Meters = 0.386 Sq. Miles

CUBIC MEASURE

1 Cu. Centimeter = 1000 Cu. Millimeters = 0.06 Cu. Inches
 1 Cu. Meter = 1,000,000 Cu. Centimeters = 35.31 Cu. Feet

TEMPERATURE

$5/9(^{\circ}\text{F} - 32) = ^{\circ}\text{C}$
 212° Fahrenheit is equivalent to 100° Celsius
 90° Fahrenheit is equivalent to 32.2° Celsius
 32° Fahrenheit is equivalent to 0° Celsius
 $9/5^{\circ}\text{C} + 32 = ^{\circ}\text{F}$

APPROXIMATE CONVERSION FACTORS

TO CHANGE	TO	MULTIPLY BY
Inches	Centimeters	2.540
Feet	Meters	0.305
Yards	Meters	0.914
Miles	Kilometers	1.609
Square Inches	Square Centimeters	6.451
Square Feet	Square Meters	0.093
Square Yards	Square Meters	0.836
Square Miles	Square Kilometers	2.590
Acres	Square Hectometers	0.405
Cubic Feet	Cubic Meters	0.028
Cubic Yards	Cubic Meters	0.765
Fluid Ounces	Milliliters	29.573
its	Liters	0.473
arts	Liters	0.946
allons	Liters	3.785
Ounces	Grams	28.349
Pounds	Kilograms	0.454
Short Tons	Metric Tons	0.907
Pound-Feet	Newton-Meters	1.356
Pounds per Square Inch	Kilopascals	6.895
Miles per Gallon	Kilometers per Liter	0.425
Miles per Hour	Kilometers per Hour	1.609

TO CHANGE	TO	MULTIPLY BY
Centimeters	Inches	0.394
Meters	Feet	3.280
Meters	Yards	1.094
Kilometers	Miles	0.621
Square Centimeters	Square Inches	0.155
Square Meters	Square Feet	10.764
Square Meters	Square Yards	1.196
Square Kilometers	Square Miles	0.386
Square Hectometers	Acres	2.471
Cubic Meters	Cubic Feet	35.315
Cubic Meters	Cubic Yards	1.308
Milliliters	Fluid Ounces	0.034
Liters	Pints	2.113
Liters	Quarts	1.057
ers	Gallons	0.264
ms	Ounces	0.035
ograms	Pounds	2.205
Metric Tons	Short Tons	1.102
Newton-Meters	Pounds-Feet	0.738
Kilopascals	Pounds per Square Inch	0.145
ometers per Liter	Miles per Gallon	2.354
ometers per Hour	Miles per Hour	0.621



PIN: 015495-000